



## iBoard 7082 XL Technical Specifications

- Power
- Sound
- External Interfaces
- Environmental Parameters
- Remote Control
- Computer Features
- Projector
- Touch System
- Installation Requirements
- Dimensions
- Warranty

IR Interactive Whiteboard 82"  
with back cabinet, computer and projector.  
iBoard IWB Software  
and iBoard Class Module included.

Certifications:



 **Power**

PARAMETER	VALUE
Power Consumption	326W
Standby Power Consumption	<= 5W
Operating voltage range	100V-240VAC 60/50Hz

 **Sound**

PARAMETER	VALUE
Nominal Power Input	10W + 10W
Maximum Power Input	15W + 15W
Rated Impedance AC	8Ω ± 15% @ 20°C, 1000Hz

 **External Interfaces**

PARAMETER	VALUE
HDMI	1
USB	2
Mic Input	1
Power Button	1
Reset Button	1
RJ45 Gigabyte LAN	1

 **Environmental Parameters**

PARAMETER	VALUE
Operating Temperature Range	0°C to + 40°C
Operating Humidity Range	15% - 85%
Storage Temperature	- 40°C to + 60°C
Storage Humidity	0% - 95%
Operating and Storage Atmospheric Pressure Range	86kpa - 104kpa
Installation	171 cm (w) x 155 cm (h)

 **Remote Control**

PARAMETER	VALUE
Remote control operation (for projector only)	<= 8m ± 30m

 **Computer Features** (subject to change, call your nearest distributor for more information.)

PARAMETER	VALUE
Processor	Intel core TM processor(Intel i3, Intel i5 or Intel i7)
Chipset	Intel QM77 or superior
Graphics	Intel integrated graphics HM4000 or superior
Wireless Communication	Integrated 802.11n WiFi
Memory	4GB DDR3 1333Mhz (up to 8GB 1600Mhz support)
Storage	1xSATA on the port, 500GB 7200rpm SATA3 drive (SSD support)
Operating System	Windows XP, Vista, 7, 8, WES 7, WES 2009, Linux
Software	iBoard Interactive Software & iBoard Class Software

 **Projector** (subject to change, call your nearest distributor for more information.)

PARAMETER	VALUE
Resolution	1024 x 768 XGA
Power supply	AC 100-240 3.70A, 50-60 Hz
Power consumption	380 W; < 1 W
Weight	5.8 Kg

 **Touch System**

PARAMETER	VALUE
Resolution	9600 x 9600
DPI	600
Active Area Dimension	147.8 cm x 115.8 cm
Active Area Diagonal	194 cm (76")
Aspect Ratio	4:3
Precision	0.1 mm
Signal Tracking Rate	8 m/s (315 p/s)
Signal Processing Rate	480 dots/s
Calibration	4, 9 or 20 points

 **Installation Requirements**

INSTRUCTIONS
The iBoard 7000 series must be installed by a trained professional installer.
An optional mounting plate is required to wall-mount the iBoard.
Ensure the wall can support the product's weight.

 **Dimensions**

PARAMETER	VALUE
Overall Size	167.0 cm x 126.0 cm
Diagonal Dimensions	208.4 cm (82")
Unit Weight (Net)	49.6 kg
Unit Weight (Gross)	65.8 kg
Package Size	179 cm x 139 cm x 35 cm

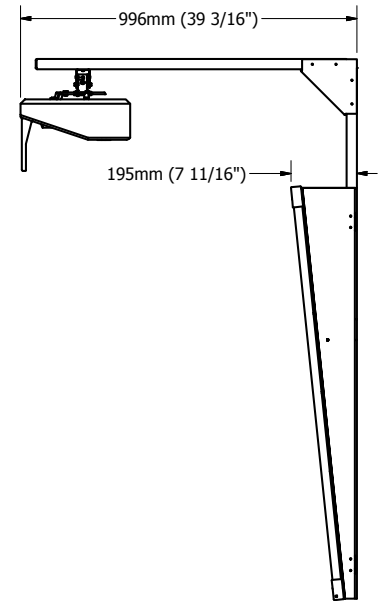
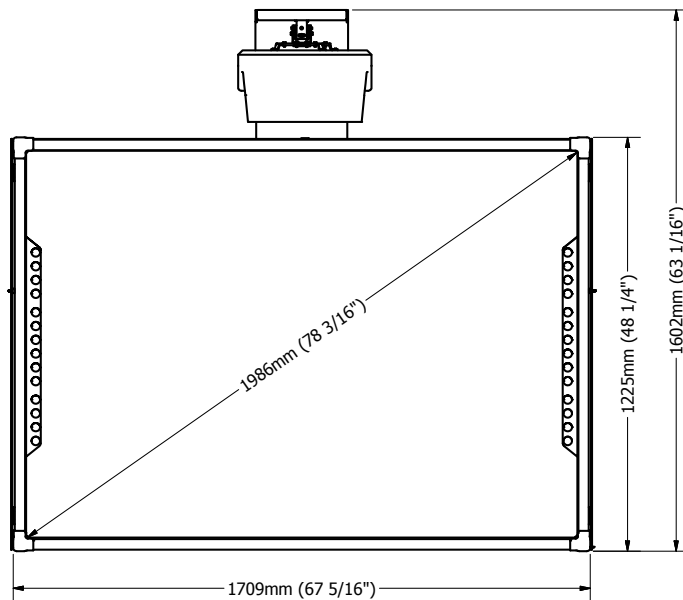

 **Warranty**

**TERMS**

One year limited warranty. Up to five years of total extended protection available.